

The information on this sheet is Private and Confidential and is the property of Crane Process Flow Technologies Limited and must not be published directly or indirectly in any manner whatsoever without the written permission of the Company and must not be used in any way detrimental to their interests.
 © Crane Process Flow Technologies

CRANE Process Flow Technologies
 A Crane Co. Company

Saunders
 The Science Inside

Title
 SCHEDULE OF LEADING DIMENSIONS FOR DN80/3.00 WEIR
 POINT OF USE 'T' BODY WITH BUTT WELD OD TUBE ENDS

Drawn RI	Date 29.09.11	UNCONTROLLED IN HARD COPY FORMAT
Checked RND	Date 21.03.12	
First Angle Projection Method E	DO NOT SCALE	Drawing No. WEB-039
		Issue. 2

MAINLINE SIZE		A		B		C		D		øE		øF		G		H		BODY WEIGHT
mm	inch	mm	inch	mm	inch	mm	inch	mm	inch	mm	inch	mm	inch	mm	inch	mm	inch	Kgs
DN80	3.00	158.8	6.25	50.8	2.00	46.5	1.83	64.0	2.52	76.2	3.00	72.9	2.87	41.1	1.62	513.6	20.22	22.3
DN100	4.00	203.2	8.00	50.8	2.00	58.8	2.31	77.0	3.03	101.6	4.00	97.38	3.83	41.1	1.62	602.4	23.72	31.2

ORIENTATION AS PER P&ID DIAGRAM FOR OPTIMUM DRAINABILITY.

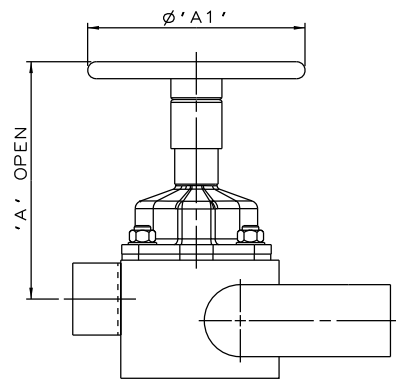

SS NON SEALED
BONNET ASSEMBLY

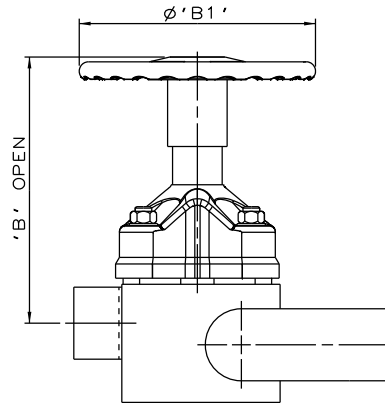

PES BONNET
ASSEMBLY

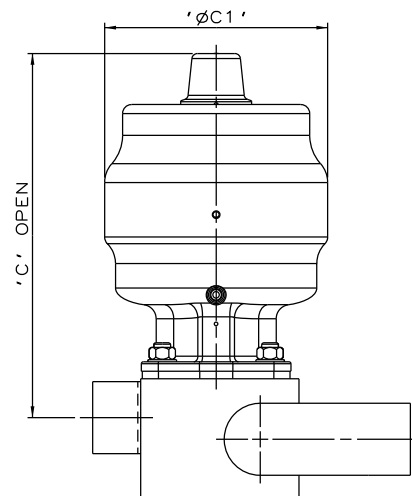

*S360 ACTUATOR

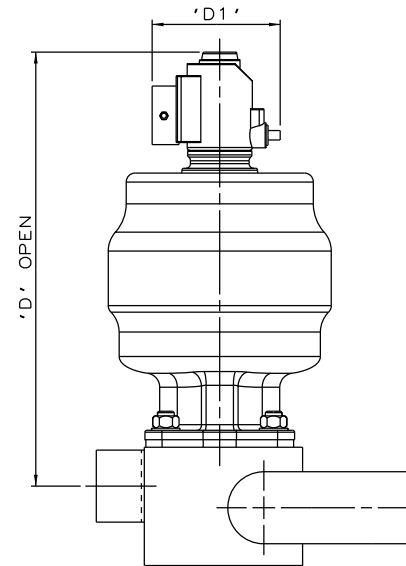

*S360 ACTUATOR
WITH I-VUE SENSOR

*DIMENSIONS SHOW MAXIMUM ENVELOPE FOR ALL MODES

MAINLINE SIZE		A		A1		B		B1		C		C1		D		D1	
mm	inch	mm	inch	mm	inch	mm	inch	mm	inch	mm	inch	mm	inch	mm	inch	mm	inch
DN80	3.00	251	9.88	230	9.05	282	11.10	250	9.84	385	15.16	236	9.29	459	18.07	135.5	5.33

The information on this sheet is Private and Confidential and is the property of Crane Process Flow Technologies Limited and must not be published directly or indirectly in any manner whatsoever without the written permission of the Company and must not be used in any way detrimental to their interests.
© Crane Process Flow Technologies

CRANE Process Flow Technologies
A Crane Co. Company

Saunders
The Science Inside

Title
SCHEDULE OF LEADING DIMENSIONS FOR DN80/3.00
WEIR POINT OF USE 'T' BODY COMPLETE WITH
BUTT WELD OD TUBE ENDS
FITTED WITH TOPWORKS OPTIONS

Drawn JRD Date 28.09.16 UNCONTROLLED IN
Checked RND Date 28.09.16 HARD COPY FORMAT

First Angle Projection  DO NOT SCALE Drawing No. WEB-039-ASSY Issue. 1